



**HAL**  
open science

## **On the Possibility of CFD Modeling of the Indoor Environment in a Vehicle**

Paul Danca, Florin Bode, Ilinca Nastase, Amina Meslem

### ► **To cite this version:**

Paul Danca, Florin Bode, Ilinca Nastase, Amina Meslem. On the Possibility of CFD Modeling of the Indoor Environment in a Vehicle. *Energy Procedia*, 2017, 112, pp.656-663. <10.1016/j.egypro.2017.03.1133>. <hal-01523119>

**HAL Id: hal-01523119**

**<https://univ-rennes.hal.science/hal-01523119v1>**

Submitted on 27 Jun 2018

**HAL** is a multi-disciplinary open access archive for the deposit and dissemination of scientific research documents, whether they are published or not. The documents may come from teaching and research institutions in France or abroad, or from public or private research centers.

L'archive ouverte pluridisciplinaire **HAL**, est destinée au dépôt et à la diffusion de documents scientifiques de niveau recherche, publiés ou non, émanant des établissements d'enseignement et de recherche français ou étrangers, des laboratoires publics ou privés.



Distributed under a Creative Commons CC BY-NC-ND 4.0 - Attribution - Non-commercial use - No Derivative Works - International License



Sustainable Solutions for Energy and Environment, EENVIRO 2016, 26-28 October 2016,  
Bucharest, Romania

## On the possibility of CFD modeling of the indoor environment in a vehicle

Paul Danca<sup>a,b</sup>, Florin Bode<sup>a,c</sup>, Ilinca Nastase<sup>\*a</sup>, Amina Meslem<sup>b</sup>

<sup>a</sup>CAMBI Research Center, Technical University of Civil Engineering of Bucharest, Bd. Pache Protopopescu 66, 021412, Bucharest, Romania

<sup>b</sup>LGCGM EA3913, Université de Rennes 1, 3 rue du Clos Courtel, 35704 Rennes Cedex 7, France

<sup>c</sup>Technical University of Cluj-Napoca, Bd. Muncii 103-105, 400641, Cluj-Napoca, Romania

---

### Abstract

Prediction of thermal conditions inside a vehicle cabin is still a challenge due to the fast transient behaviour of physical factors influencing the boundaries of the vehicular space. In order to gain knowledge and to propose new models of air flow and thermal characteristics on one hand and new adapted thermal comfort indices on the other hand, researchers need to perform parametric studies. In this case a CFD model can be a very powerful tool which let us simulate the environmental conditions in the vehicle cabin and test different strategies of ventilation and their impact on human thermal comfort. The challenge when using a CFD software is to produce results that can be trusted. This study tries to evaluate a simple approach of calibrating and validating a CFD model that reproduces the thermal environment and the flow dynamics inside a vehicular cabin. As this study is a part of a project intended to evaluate different strategies of cabin ventilation from the point of view of the thermal comfort, we will compare experimental data regarding air velocities and temperatures as well as the corresponding local comfort indices.

© 2017 The Authors. Published by Elsevier Ltd. This is an open access article under the CC BY-NC-ND license (<http://creativecommons.org/licenses/by-nc-nd/4.0/>).

Peer-review under responsibility of the organizing committee of the international conference on Sustainable Solutions for Energy and Environment 2016

*Keywords:* Passenger Cabin, Computational Fluid Dynamics, Air Flow, Thermal Comfort

---

\* Corresponding author. Tel.: +4-073-392-0679

E-mail address: [ilincanastase@gmail.com](mailto:ilincanastase@gmail.com)

## 1. Introduction

The main characteristics of the vehicular in-cabin environment that complicate the human thermal comfort determination and prediction are due to its thermal transient values and time gradients. Additionally, the non-uniform thermal environment associated with the high localized air velocity, the in-cabin air temperature distribution, the solar heat flux and the radiative heat flux from surrounding interior surfaces, all further complicate such predictions [7, 9]. Furthermore, unlike air conditioned buildings, the vehicle in-cabin climate is dominated by thermal transient conditions rather than steady-state conditions. Other issues include the psychological as well as physiological differences among the passengers. Finally, the vehicular in-cabin environment is affected by a large number of parameters that include the different interior surfaces and air temperatures, the air velocity distribution over the interior complex geometries, the relative humidity, the solar irradiance and its scattering over the different material types and surface niches in the cabin, the angles of its incidence, the type of passengers clothes, etc. Also many of these parameters are dependent with unknown relationships [6]. This not only complicates any modelling effort, but also any experimental work.

Thermal comfort of vehicular occupants is important due to the rising attention towards comfortable mobility, in addition to the growing time that people spend in vehicles. Comfortable vehicular climate control in many cases helps to reduce driver's stress and thus contributes to a safer driving. In addition, today's demands for energy efficiency and performance, have led to an increased interest in investigating and analyzing the system and design requirements for good quality of the vehicular environment. The need to reduce the heat loads that enter passenger compartments has become an important issue in the early stages of vehicle design, also achieving an improved thermal comfort system will lead to substantial cost reductions.

Thermal comfort is the state of a person who expresses a sense of well-being, but as indicated by K. Slater in his book "Human Comfort" from 1985, *thermal comfort is a term difficult to define and that a universal definition of its meaning is almost impossible to obtain*[2]. In the same environment, more individuals can give several different expressions of their feelings of comfort. Thus, an appropriate thermal comfort is obtained when the human body can maintain constant body core temperature (around 36.7 °C) without an important intervention of its thermoregulatory mechanisms. Fanger [3] showed that *"the human thermoregulatory system is quite efficient and tends primarily to ensure thermal equilibrium without an explicit effort and then adjust its reaction to external stimuli"*. Generally we can differentiate between factors connected with the human organism like the age, gender, weight, metabolic rate, type of activity, etc., factors connected with the clothing like thermal resistance, material structure, number of layers, and factors connected with the environment like air temperature, velocity, humidity, pressure and turbulence intensity and frequency [10-13]. Extensive investigations and experiments involving numerous subjects have resulted in methods for predicting the degree of thermal discomfort of people exposed to a still and homogenous thermal environment on steady state conditions. However, it is currently recognized that even in buildings pure steady-state conditions are rarely encountered in practice. For strongly non-uniform and transient environments like in vehicular cabins, the previous cited studies and standards are not applicable for obtaining reliable results.

The standard that is used nowadays to assess thermal comfort in vehicles is EN ISO 14505 [4-6]. This standards is structured in three parts that are proposing the following indicators for assessing thermal comfort: PMV (Predicted Mean Vote), PPD (Predicted Percentage of Dissatisfied)[4], TSV (Thermal Sensation Vote)[6],  $t_{eq}$  (equivalent temperature)[5]. PMV and PPD are the same indices proposed for moderate environments and developed under the aforementioned steady-state conditions for buildings. The other two indices are the equivalent temperature that may assess local thermal discomfort and the TSV which is a subjective index.

In practice, experimental subjective studies show that there might be important differences between the thermal state expressed by real passengers and the predicted state of comfort given by the indices proposed by standards. In order to study the relationship between the response and independent design variables, a large number of experiments are undoubtedly required. This will be reflected on the increased total cost of the studies, which is particularly true in the case of employing physical experimentations. Therefore, numerical investigations such as those accomplished by Computational Fluid Dynamics (CFD) have been gaining immense popularity within the automotive industry since the past few decades. In the particular case of a vehicular environment, setting up a correct CFD model could be quite complicated given the requirement of validation and calibration compared to experimental data.

This study is a part of a larger research program which aims on one hand to deepen the knowledge on thermal comfort and its numerical methods of prediction and on the other hand, to analyze the real role played by transient environment parameters (such as radiant temperature of interior surfaces, air velocity pulsation, local air turbulence) in perceiving thermal comfort and in its estimation. Our goal is to develop a realistic CFD model of a vehicular environment with passengers. The human body model of the passengers will have anatomic shape and will be coupled with a thermoregulatory model. The advanced combined thermoregulatory-CFD model will have the capability to predict thermal comfort in a variety of cases and to reveal more details of the interaction between the body and its environment. In this article we present the first step which consisted in the setup of the model for the cabin car. We wanted to check if we can reproduce the in-cabin environment without passengers and find data from the CFD model similar to those of experimental measurements.

## 2. Methodology

Our experimental facility is composed of a Renault Megane hatchback car with a 1.4 liter engine, with a manual ventilation/conditioning system. This system has three types of discharge grilles: one at the dashboard level directed to the windshield; four grilles that are directed to the passengers from the front part of the vehicle and four discharge grilles that are directed to the legs of both front and the rear passengers. For the approach presented in this article we did not dispose of a climatic chamber for putting our vehicle in order to obtain controlled conditions. However the car was kept inside a hall in which no solar radiation penetrates and were indoor conditions varied slower than outside. The main reason for this choice was related to our desire to completely decouple the in-cabin conditions from the solar radiation effect during the first steps of developing and validating our CFD model. The cabin interior is a very complex geometry compared with other indoor spaces. It has less space and much higher air change rates and higher air velocities in the vicinity of the body.

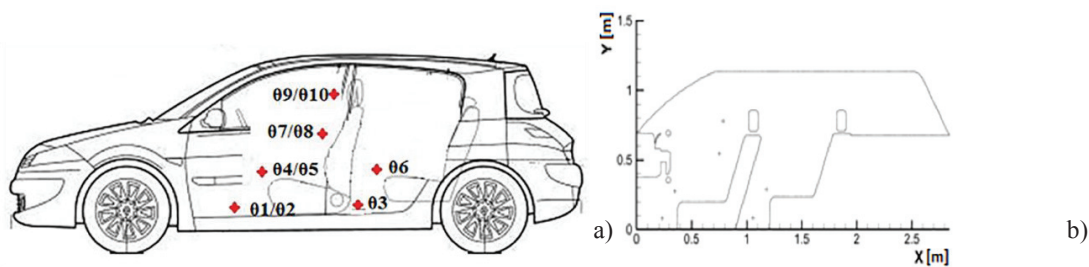

Fig. 1. a). K – type thermocouples at different passengers position b). monitored points in CFD model

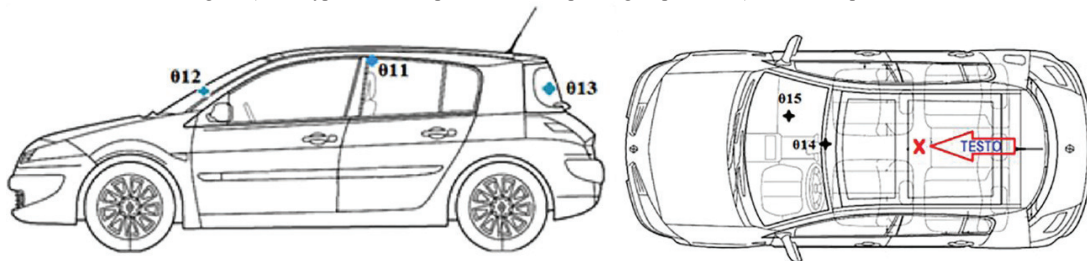

Fig. 2. Measuring points with K-type thermocouples on different cabin surfaces

Most of the experimental studies for the numerical validation of the passengers' compartment models that are available in the literature have been conducted in spaces in which was attempted to maintain constant the values of thermal comfort parameters. In our case, the boundary conditions imposed to the model were data obtained through measurements on the defining surfaces and related to the discharge volumetric air flows. In the same experimental campaign other data were acquired in the cabin in order to allow us further comparisons for the validation of the numerical model.

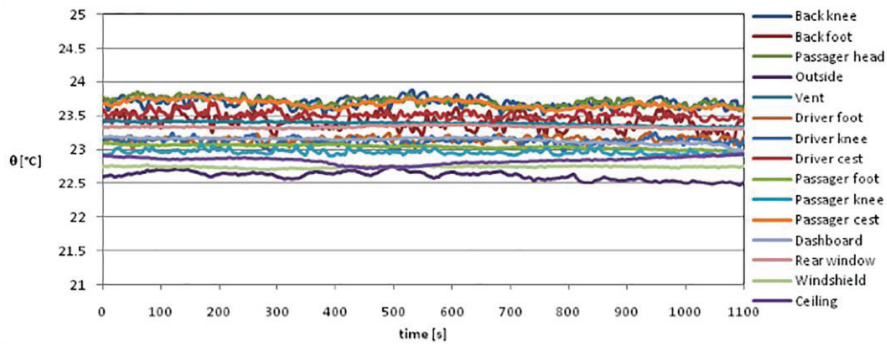

Fig. 3. Example of temperature variation inside the cabin for the considered boundary conditions

Table. 1 Sensors positions legend

No	Place of installation
01	Diver foot
02	Front Passenger foot
03	Back foot
04	Driver knee
05	Front Passenger knee
06	Back knee
07	Driver chest
08	Front Passenger chest
09	Driver face
010	Front Passenger face
011	Ceiling
012	Windshield
013	Rear window
014	Vent
015	Dashboard

Table. 2. Measurement tools used, ranges and precisions

Measuring instrument	Parameters	Measurement range	Precision
TESTO 480	Relative humidity	0 ÷ 100 % RH	± 2 RH
	Temperature	0 ÷ +50 °C	± 0.5 °C
	Mean radiant temperature	0 ÷ 120 °C	± 0.5 °C
	Air velocity	0 ÷ 5 m/s	± 0.03 m/s
Almemo 2890-9 + thermocouples K-type	Temperature	-270 ÷ +1372°C	????
TSI Flow meter LCA 301	Air velocity	0.25 ÷ 30 m/s	± 0.02 m/s

Experimental data was acquired in the Renault Megane automobile (Fig. 1 and 2), placed in the aforementioned hall, protected from outside weather conditions. Measuring sessions were conducted in days with temperatures relatively similar, so both outside in the hall and inside cabin temperature has constant values

between 21 and 24.5 °C. For the choice of our boundary conditions we considered only cases where the temperature evolutions inside the cabin car were constant in time (see Fig. 3). It can be seen that the variation during the considered measurement session is insignificant for all the measurement points. A network of 15 K-type thermocouples was used to monitor variation of temperature on different surfaces of vehicle and in different places where normally human body parts are (head, chest, knee, foot). The K-thermocouples were positioned as in Table. 1, Fig. 1. and Fig. 2. Various other sensors (air velocity, relative humidity and mean radiant temperature) were installed in vehicle cabin to monitor other parameters which influence the thermal comfort. To obtain the air flow rates, a TSI Flow meter was placed in front of each discharge grille. Also in places where human body parts should be, the air speed values were measured with an omnidirectional probe and the local temperature values with a thermistor that is embedded in the same instrument. The two sensors are part of a TESTO 480 instrument.

During the experimental approach a total number of 12 measurement sessions were carried out, each session lasting 50 minutes. During measurements, we used three ventilation strategies: only body discharge grilles – *dashboard*, only foot discharge grilles – *feet*, and body and foot discharge grilles – *dashboard and feet*. We also changed the air flow rate according to all four stages (I –IV) of the car ventilation system.

We checked which are the “*maximum allowable mean air speeds*” - according to the guidelines given by ISO 7730 [13] - as a function of the local air temperature (see Table. 3) and the turbulence intensity (we considered the maximum value which is 40 % according to ISO 7730). We found that, in the third and fourth flow rate position of ventilation system, the measured velocity in cabin at the body levels was higher than the maximum allowable velocity and an unpleasant draft sensation was created. In conclusion we decided to take into account only the values of parameters measured for the second air flow rate position of vehicle ventilation system.

Table. 3. Air velocity at different body parts

Air grilles position	Dashboard				Feet				Dashboard and feet			
	V1	V2	V3	V4	V1	V2	V3	V4	V1	V2	V3	V4
Velocity position												
Unit	[m/s]	[m/s]	[m/s]	[m/s]	[m/s]	[m/s]	[m/s]	[m/s]	[m/s]	[m/s]	[m/s]	[m/s]
Passenger head	0.08	0.12	0.15	0.19	0.03	0.05	0.13	0.21	0.06	0.07	0.20	0.17
Driver chest	0.12	0.13	0.12	0.12	0.05	0.05	0.17	0.21	0.06	0.11	0.24	0.23
Driver knee	0.06	0.08	0.12	0.12	0.06	0.07	0.09	0.09	0.04	0.07	0.15	0.12
Driver foot	0.08	0.17	0.16	0.15	0.15	0.16	0.23	0.24	0.08	0.15	0.17	0.19
Passenger head	0.10	0.10	0.13	0.14	0.05	0.07	0.13	0.13	0.07	0.06	0.09	0.15
Passenger chest	0.08	0.11	0.15	0.15	0.05	0.06	0.16	0.17	0.06	0.08	0.12	0.13
Passenger knee	0.06	0.07	0.1	0.09	0.03	0.07	0.25	0.22	0.03	0.05	0.11	0.11
Passenger foot	0.10	0.10	0.23	0.24	0.27	0.26	0.62	0.51	0.20	0.31	0.32	0.41
Back knee	0.10	0.10	0.12	0.12	0.09	0.15	0.22	0.24	0.14	0.21	0.21	0.16
Back foot	0.14	0.20	0.30	0.25	0.32	0.39	0.85	0.98	0.20	0.34	0.42	0.44

The numerical grid (Fig. 4.) was composed of 6 million tetrahedral elements and the boundary layer consists of 5 layers. A grid independence test was carried out on five different grids: 1.1, 2.5, 4.6, 6 and 8.2 million elements. The numerical results obtained with the 6 and 8.2 million elements showed small differences so we choose the 6 million elements grid from computational reasons.

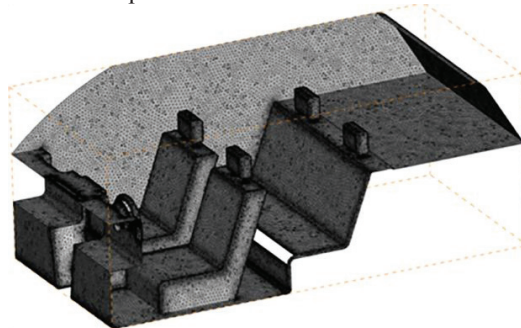

Fig. 4. Computational grid detail

For the boundary conditions we imposed a mass flow rate of 0.042kg/s on the central grills and a mass flow rate of 0.039 kg/s on the sides' grills. Air temperature at the inlet grills was imposed as 23 °C. The inlet turbulence intensity was imposed as 4.11% being calculated using the empirical relation proposed by Jaramillo [14]:  $I = 0.16Re^{-1/8}$ . The Reynolds number at the exit of the central orifices based on stream wise mean velocity and equivalent diameter ( $D_{e1} = 0.093$  m) was  $Re = 17763$ , and for the sides grills  $Re = 13924$  ( $D_{e2} = 0.073$  m). For the pressure-velocity coupling we utilized the COULPED algorithm. A second order upwind scheme was used to calculate the convective terms in the equations, integrated with the finite volume method. For the near-wall modeling, the standard wall function was used. The chosen turbulence model used for the numerical simulation was RNG k- $\epsilon$ , because the overall performance of this model is one of the best for the indoor environment modelling[15][16].

### 3. Results and discussions

The results that are discussed here were obtained in the case of the second stage of flow rates only for blowing through the grilles on the dashboard of the car. In figures 5 and 6 are presented the distributions of the air velocity magnitudes and of the in plane vectors as well as of the air temperature in two longitudinal planes of the car passing through the median plane of the passenger seats.

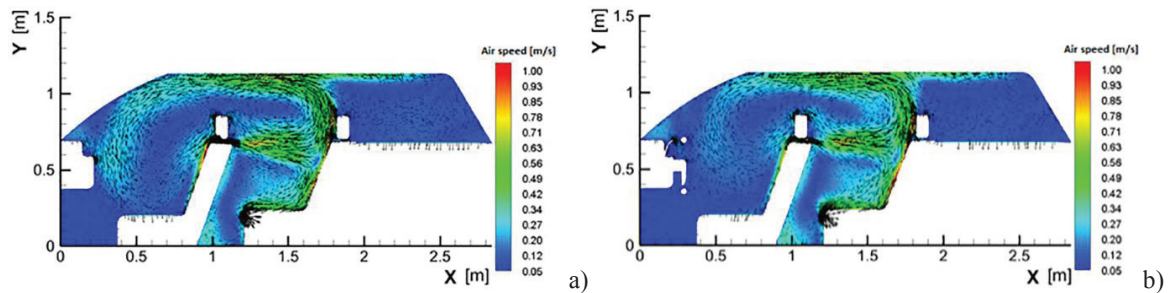

Fig. 5. Distributions of the velocity magnitude and of the in plane vectors: a). left part of the car; b). right part of the car

In Fig. 5 can be seen that the strong turbulent flows from the inlets were blocked by the driver and the right front passenger seats, thus forming a local recirculation in the front part of the compartment. Also a strong recirculation can be seen in the rear part of the cabin. This phenomenon is related to the air passing in the central part of the cabin between the two front seats and on the lateral parts of the cabin between the two seats and the left and right doors. The maximum values of the air speed inside the cockpit are situated around 1m/s. Values as high as 3.6m/s could be recorded in the rear part of the car also. The flows are almost symmetrically distributed in the cabin. The imposed values were those measured in the real car. In Table 4 is given a comparison between values extracted from the numerical model and the measured air speeds in the same points inside the cabin.

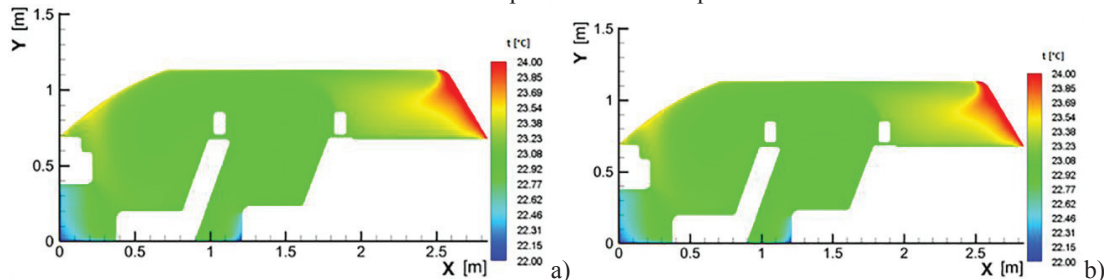

Fig. 6. Distributions of the air temperature: a)left side of the car; b)right part of the car

Very close values between the model and the experimental data were obtained for the air speed, excepted the region close to the feet of the passengers where higher values were recorded for the measurements. There are

several explanations to this finding. First of them is related to the boundary conditions at the air grilles. Indeed we imposed uniform distributions of air temperatures and air velocities. In this case the air vents next to the feet were considered to be fully closed while in the real car a very small amount of air is introduced always through these air grilles. At some points the difference between the experimental and numerical data lies in the measurement incertitude of the velocity sensor. In Fig. 7 are represented the isocontours of three velocities with different colors: with red 1.8 m/s; with green 1.3 m/s; with blue 0.8 m/s.

In Table 4 are also given comparisons between the numerical and experimental values of the air temperature with a better agreement. In the numerical case the temperature variation was found to be between 22.2 °C and 23.2 °C in the same range as in the experimental case. Very good agreement was found between the numerical and the experimental data.

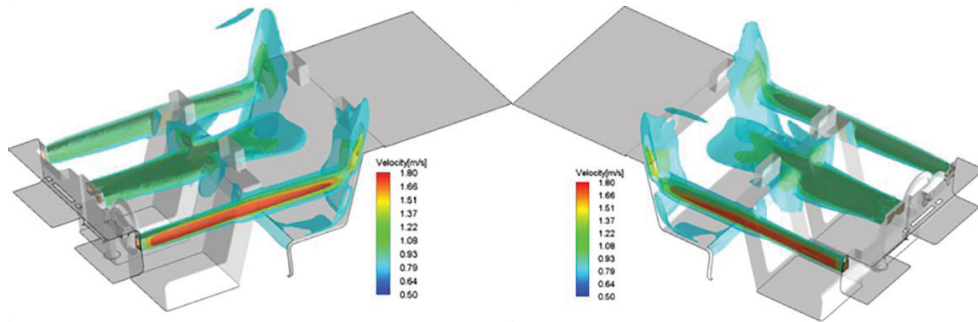

Fig. 7. Three iso-contours of velocity (red - 1.8 m/s, green 1.3 m/s, blue 0.8 m/s)

Table 4. Comparison between vales of velocity, temperature and thermal indexes

Point/parameter of measurement	v [m/s]		$\theta$ [°C]		PMV		PPD	
	Exp	CFD	Exp	CFD	Exp	CFD	Exp	CFD
Passenger Head	0.1	0.11	23.62	23.30	-0.38	-0.48	8.11	9.80
Driver Chest	0.13	0.15	23.3	23.07	-0.54	-0.65	11.24	13.91
Passenger Chest	0.11	0.14	23.61	23.04	-0.42	-0.63	8.73	13.26
Driver Knee	0.08	0.07	22.41	22.89	-0.58	-0.48	12.03	9.91
Passenger Knee	0.07	0.09	22.94	23.05	-0.47	-0.45	9.71	9.29
Back Knee	0.1	0.11	23.53	22.88	-0.40	-0.55	8.37	11.43
Driver Foot	0.17	0.03	22.2	23.05	-0.88	-0.45	21.51	9.29
Passenger Foot	0.1	0.06	22.57	22.97	-0.57	-0.47	11.79	9.59
Back Foot	0.2	0.18	23.44	22.76	-0.70	-0.79	15.29	18.40

PMV and PPD indices were also evaluated in both cases, using constant metabolic rate  $M=1\text{Met}$ , constant cloth insulation resistance  $I_{cl} = 0.7$  and constant relative humidity  $RH=60\%$ . For the experimental case we considered a constant turbulence intensity  $Tu=40\%$  as prescribed by ISO 7730 [13] in the case were the turbulence intensity cannot be measured. Comparing values thermal comfort PMV and PPD indices, some differences can be observed. The values recorded for the PMV display a “discomfort” indication in the direction of “cold sensation”. The differences between the numerical and experimental data are amplified at some points (see Table 4) especially where slightly higher values of the air speed and smaller values of the temperature were found in the numerical model. We have to note that the range of the air speeds and of the temperatures are all corresponding to moderate environments as prescribed by EN ISO 14505/1 in order to apply the model from EN ISO 7730. We note also that air speeds are very low compared to usual conditions inside the cockpit of a vehicle. This clearly shows in our opinion the inadequacy of the PMV model for classifying such an environment.

#### 4. Conclusions

This study tries to evaluate a simple approach of calibrating and validating a CFD model that reproduces the thermal environment and the flow dynamics inside a vehicular cabin. As this study is only a small part of a project intended to evaluate different strategies of cabin ventilation from the point of view of the thermal comfort, we compared experimental data regarding air velocities and temperatures as well as the corresponding local comfort indices. A good agreement between the CFD model data and the measured data inside a real vehicle was obtained. This way we will be able to study numerically the influence of several parameters on the in cabin environment. We also showed in this paper that the PMV/PPD model is inadequate to be taken into account as a quantitative assessing tool for vehicular spaces.

#### Acknowledgements

This work was supported by a grant of the Romanian National Authority for Scientific Research, CNCS, UEFISCDI, project number PN-II-PT-PCCA-2011-3.2-0512 (92/2012) The authors would also like to acknowledge the financial support for this work through the grant -Bourse Doctorale Régionale- from the Région Bretagne, France.

#### References

- [1] DIRECTIVE 2009/33/EC of the European Parliament and of the Council of 23 April 2009 on the promotion of clean and energy-efficient road transport vehicles.
- [2] K. Slater, Human Comfort, 1985.
- [3] P.O. Fanger, *Thermal Comfort-Analysis and Applications in Environmental Engineering*, in: C.D.T. Press. (Ed.), 1970.
- [4] ISO, Ergonomics of the thermal environment - Evaluation of thermal environments in vehicles Part 1: Principles and methods for assessment of thermal stress, in: ISO 14505-1:2007, 2007.
- [5] ISO, Ergonomics of the thermal environment - Evaluation of thermal environments in vehicles - Part 2: Determination of equivalent temperature in: ISO 14505-2:2006, 2006.
- [6] ISO, Ergonomics of the thermal environment -Evaluation of thermal environments in vehicles Part 3: Evaluation of thermal comfort using human subjects, in: ISO 14505-3:2006, 2006.
- [7] A. Vartires, A. Dogeanu, P. Dancă., The human thermal comfort evaluation inside the passenger compartment, Air pollution and climate change, Energy and Clean Technologies Conference Proceedings (2015) 8.
- [8] P. Danca, A. Vartires, Thermal comfort assessment using human subjects; , Machines, Technologies, Materials International Journal, International Journal for Science, technics and innovations for the industry, (2015) 4.
- [9] W. Zhang, J. Chen, F. Lan, Experimental study on occupant's thermal responses under the non-uniform conditions in vehicle cabin during the heating period Chinese Journal of Mechanical Engineering, (2014 ).
- [10] M.S. Oh, J.H. Ahn, D.W. Kim, D.S. Jang, Y. Kim, Thermal comfort and energy saving in a vehicle compartment using a localized air-conditioning system, Applied Energy, 133 (2014) 14-21.
- [11] H. Zhang, L. Dai, G. Xu, Y. Li, W. Chen, W. Tao, Studies of air-flow and temperature fields inside a passenger compartment for improving thermal comfort and saving energy. Part II: Simulation results and discussion, Applied Thermal Engineering, 29 (2009) 2028-2036.
- [12] J.H. Moon, J.W. Lee, C.H. Jeong, S.H. Lee, Thermal comfort analysis in a passenger compartment considering the solar radiation effect, International Journal of Thermal Sciences, 107 (2016) 77-88.
- [13] E. ISO, ISO 7730 - Ergonomics of the thermal environment – Analytical determination and interpretation of thermal comfort using calculation of the PMV and PPD indices and local thermal comfort criteria, (2005).
- [14] J.E. Jaramillo, C.D. Perez-Segarra, I. Rodriguez, A. Oliva, Numerical study of plane and round impinging jets using RANS models, Numer. Heat Transfer Part B 54 (2008) 213-237.
- [15] Q.Y. Chen, Z. Zhang, W. Zuo, Computational fluid dynamics for indoor environment modeling: past, present and future, in: XXV UIT National Heat Transfer Conference, Trieste, Italy, 2007.
- [16] Z. Zhang, J.Z. Zhai, Q. Chen, Evaluation of various CFD models in predicting room airflow and turbulence, in: ROOMVENT, Helsinki, Finland, 2007.