



**HAL**  
open science

## **NNT mutations: a cause of primary adrenal insufficiency, oxidative stress and extra-adrenal defects**

Florence Roucher-Boulez, Delphine Mallet-Moták, Dinane Samara-Boustani, Houweyda Jilani, Asmahane Ladjouze, Pierre François Souchon, Dominique Simon, Sylvie Nivot, Claudine Heinrichs, Maryline Ronze, et al.

### ► **To cite this version:**

Florence Roucher-Boulez, Delphine Mallet-Moták, Dinane Samara-Boustani, Houweyda Jilani, Asmahane Ladjouze, et al. NNT mutations: a cause of primary adrenal insufficiency, oxidative stress and extra-adrenal defects. *European Journal of Endocrinology*, 2016, 175, pp.73-84. 10.1530/EJE-16-0056. hal-01321410

**HAL Id: hal-01321410**

**<https://univ-rennes.hal.science/hal-01321410>**

Submitted on 14 Oct 2016

**HAL** is a multi-disciplinary open access archive for the deposit and dissemination of scientific research documents, whether they are published or not. The documents may come from teaching and research institutions in France or abroad, or from public or private research centers.

L'archive ouverte pluridisciplinaire **HAL**, est destinée au dépôt et à la diffusion de documents scientifiques de niveau recherche, publiés ou non, émanant des établissements d'enseignement et de recherche français ou étrangers, des laboratoires publics ou privés.

1 **NNT mutations: a cause of primary adrenal insufficiency, oxidative stress and extra-adrenal**  
2 **defects**

3 Florence Roucher-Boulez<sup>1,2,\*</sup>, Delphine Mallet-Motak<sup>1</sup>, Dinane Samara-Boustani<sup>3</sup>, Houweyda Jilani<sup>1</sup>,  
4 Asmahane Ladjouze<sup>4</sup>, Pierre-François Souchon<sup>5</sup>, Dominique Simon<sup>6</sup>, Sylvie Nivot<sup>7</sup>, Claudine  
5 Heinrichs<sup>8</sup>, Maryline Ronze<sup>9</sup>, Xavier Bertagna<sup>10</sup>, Laure Groisne<sup>11</sup>, Bruno Leheup<sup>12</sup>, Catherine Naud-  
6 Saudreau<sup>13</sup>, Gilles Blondin<sup>13</sup>, Christine Lefevre<sup>14</sup>, Laetitia Lemarchand<sup>15</sup>, Yves Morel<sup>1,2</sup>

7

8 <sup>1</sup>Molecular Endocrinology and Rare Diseases, Lyon University Hospital, Bron, France;

9 <sup>2</sup>Claude Bernard Lyon 1 University, Lyon, France;

10 <sup>3</sup>Pediatric Endocrinology, Gynecology and Diabetology, Necker University Hospital, Paris, France;

11 <sup>4</sup>Pediatric Department, Bab El Oued University Hospital, Alger, Algeria;

12 <sup>5</sup>Pediatric Endocrinology and Diabetology, American Memorial Hospital, Reims, France;

13 <sup>6</sup>Pediatric Endocrinology, Robert Debré Hospital, Paris, France;

14 <sup>7</sup>Department of Pediatrics, Rennes Teaching Hospital, Rennes, France;

15 <sup>8</sup>Pediatric Endocrinology, Queen Fabiola Children's University Hospital, Brussels, Belgium;

16 <sup>9</sup>Endocrinology Department, L.-Hussel Hospital, Vienne, France;

17 <sup>10</sup>Endocrinology Department, Cochin University Hospital, Paris, France;

18 <sup>11</sup>Endocrinology Department, Lyon University Hospital, Bron-Lyon, France;

19 <sup>12</sup>Paediatric and Clinical Genetic Department, Nancy University Hospital, Vandoeuvre les Nancy,  
20 France;

21 <sup>13</sup>Pediatric Endocrinology and Diabetology, Bretagne Sud Hospital Center, Lorient, France;

22 <sup>14</sup>Pediatric Endocrinology, Jeanne de Flandre Hospital, Lille, France;

23 <sup>15</sup>Pediatric Department, La Rochelle-Ré-Aunis Hospital Group, La Rochelle, France.

24

25 **\*Corresponding author:**

26 Florence Roucher-Boulez

27 Laboratoire d'Endocrinologie Moléculaire et Maladies Rares,

28 Centre de Biologie et de Pathologie Est, 59 Bd Pinel, 69677 Bron Cedex, France

29 Phone: +33 (0)4 72 12 96 79

30 Fax: +33 (0)4 72 12 97 20

31 E-mail: [florence.roucher@chu-lyon.fr](mailto:florence.roucher@chu-lyon.fr)

32 **Short title:** *NNT*, adrenal and extra-adrenal defects

33 **Key words:** nicotinamide nucleotide transhydrogenase, oxidative stress, primary adrenal  
34 insufficiency, massive parallel sequencing, follow-up

35 **Word count:**

36 Text word count: 3880

37 Abstract word count: 239

38 **References:** 42

39 **Tables:** 2

40 **Figures:** 4

41

Accepted manuscript

42 **ABSTRACT**

43 **Objective:** *NNT* (nicotinamide nucleotide transhydrogenase), one of several genes recently discovered  
44 in familial glucocorticoid deficiencies (FGD), is involved in reactive oxygen species detoxification,  
45 suggesting that extra-adrenal manifestations may occur, due to the sensitivity to oxidative stress of  
46 other organs rich in mitochondria. Here, we sought to identify *NNT* mutations in a large cohort of  
47 patients with primary congenital adrenal insufficiency without molecular etiology and evaluate the  
48 degree of adrenal insufficiency and onset of extra-adrenal damages.

49 **Methods:** Sanger or massive parallel sequencing of *NNT* and patient monitoring.

50 **Results:** Homozygous or compound heterozygous *NNT* mutations occurred frequently (26%, 13  
51 unrelated families, 18 patients) in our cohort. Seven new mutations were identified: p.Met337Val,  
52 p.Ala863Glu, c.3G>A (p.Met1?), p.Arg129\*, p.Arg379\*, p.Val665Profs\*29, and p.Ala704Serfs\*19.  
53 The most frequent mutation, p.Arg129\*, was found recurrently in patients from Algeria. Most patients  
54 were diagnosed belatedly (8-18 months) after presenting severe hypoglycemia; others experiencing  
55 stress conditions were diagnosed earlier. Five patients also had mineralocorticoid deficiency at onset.  
56 One patient had congenital hypothyroidism and two cryptorchidism. In follow-up, we noticed  
57 gonadotropic and genitalia impairments (precocious puberty, testicular inclusions, interstitial Leydig  
58 cell adenoma, azoospermia), hypothyroidism and one hypertrophic cardiomyopathy. Intrafamilial  
59 phenotype heterogeneity was observed.

60 **Conclusions:** *NNT* should be sequenced, not only in FGD, but also in all primary adrenal  
61 insufficiencies for which the most frequent etiologies have been ruled out. As *NNT* is involved in  
62 oxidative stress, careful follow-up is needed to evaluate mineralocorticoid biosynthesis extent, and  
63 gonadal, heart and thyroid function.

64

## 65 INTRODUCTION

66 Primary adrenal insufficiency (PAI) is a life threatening disorder. Three types can occur: isolated  
67 mineralocorticoid deficiency, isolated glucocorticoid deficiency, or combined mineralocorticoid and  
68 glucocorticoid deficiency (global adrenal insufficiency). Glucocorticoid deficiencies, also called  
69 ACTH resistance syndromes, are autosomal recessive disorders. They include familial glucocorticoid  
70 deficiency (FGD) (OMIM#202200) and triple A syndrome (AAAS) (OMIM#231550), also known as  
71 Allgrove syndrome<sup>1, 2</sup>. Patients present episodes of hypoglycemia in the neonatal period or early  
72 childhood with low or unquantifiable cortisol, elevated ACTH levels and normal aldosterone and  
73 plasma renin measurements. Until 2012, only a half of FGD cases could be explained by homozygous  
74 or compound heterozygous mutations in genes involved in the steroidogenic pathway: *MC2R* (25%),  
75 *MRAP* (20%), *STAR* (5%) and more rarely *CYP11A1*<sup>3-7</sup>. Over the last three years, thanks to whole  
76 exome sequencing, three more causative genes have been discovered: *MCM4* (*mini chromosome*  
77 *maintenance deficient 4 homologue*), *NNT* (*Nicotinamide Nucleotide Transhydrogenase*) and *TXNRD2*  
78 (*Thioredoxin reductase 2*)<sup>8-10</sup>.

79 As these genes encode proteins that work together for reactive oxygen species (ROS) detoxification or  
80 DNA replication, the spectrum of pathogenic mechanisms causing PAI is not limited to genes  
81 involved in adrenal development and steroidogenesis.

82 The incidence of *NNT* gene mutations in Clark et al's FGD cohort was around 10% (15 families) and  
83 no predominant mutation was reported (21 private mutations)<sup>9</sup>. Twelve more families have been  
84 reported (12 additional mutations), some with mineralocorticoid defects<sup>11-16</sup>.

85 *NNT* encodes an integral protein of the inner mitochondrial membrane that acts as a proton pumping  
86 transhydrogenase<sup>17</sup>. In prokaryotic cells, the enzyme is composed of two or three different subunits,  
87 whereas in eukaryotic cells, it is usually composed of a single subunit. The active form of the enzyme  
88 is always a homodimer of approximately 220 kDa. All NNTs show a similar structure with three major  
89 domains. Domain I contains the hydrophilic NAD(H) binding site and domain III, the hydrophilic  
90 NADP(H) binding sites. Domain II constitutes the hydrophobic transmembrane part of the enzyme  
91 that connects domains I and III and forms the proton channel<sup>18</sup>. NNT supplies the high concentrations  
92 of NADPH needed for glutathione and thioredoxin antioxidant systems involving enzymes such as

93 GPX1 (glutathione peroxidase 1), TXNRD2 and PRDX3 (peroxiredoxin 3). NADPH is a cofactor of  
94 P450 enzymes, notably in steroidogenesis<sup>19-22</sup> (**Figure 1**).

95 Meimaridou *et al* showed reduced, basal and ACTH-stimulated corticosterone, revealing impaired  
96 steroidogenesis in C57BL/6J mice with a spontaneous *NNT* mutation (an in-frame 5 exon deletion).  
97 Furthermore, they showed increased ROS levels in an *NNT* knock-down human adrenocortical cell  
98 line<sup>9</sup>. Oxidative stress impedes steroidogenesis, which in turn induces more oxidative stress resulting  
99 from electron leaks throughout the steroidogenic pathway. Why it affects adrenal hormone production  
100 preferentially remains unknown. All tissues rich in mitochondria may be affected, resulting in a wide  
101 spectrum of diseases. Phenotypically, C57BL/6J mice do not have adrenal defects but show glucose  
102 intolerance and impaired insulin secretion<sup>23</sup>. At present, in humans, *NNT* mutations are known to be  
103 associated with adrenal insufficiency. Additionally, relationships between decreased *NNT* activity,  
104 modified mitochondrial redox regulation and cardiac failure have been recently reported<sup>24-26</sup>.

105 The aim of our study was to screen for *NNT* mutations in fifty families with PAI with no identified  
106 molecular etiologies and to perform a careful follow-up so as to identify any extra-adrenal defects. We  
107 found thirteen families (eighteen patients) with *NNT* mutations: thirteen patients were diagnosed with  
108 FGD and five with global adrenal insufficiency at onset. A range of functions, i.e.,  
109 adrenal/mineralocorticoid, puberty, fertility, heart, pancreatic, thyroid and growth, were subjected to  
110 long-term monitoring.

111

## 112 **PATIENTS AND METHODS**

### 113 **Patients**

114 The *NNT* gene was analyzed in fifty patients with primary adrenal insufficiency with no molecular  
115 diagnosis. Informed consent was provided by all enrolled patients and the study was conducted in  
116 accordance with the principles of the Declaration of Helsinki. Very long-chain fatty acids in boys and  
117 17-hydroxyprogesterone in all patients were either within normal limits or low, excluding  
118 adrenoleukodystrophy and 21-hydroxylase deficiency, and adrenal autoantibodies were negative,  
119 excluding an autoimmune disorder. Mutations in *STAR*, *CYP11A1*, *MC2R* and *MRAP* were excluded  
120 by Sanger sequencing, as were those in *NROB1* for boys.

### 121 **Molecular genetic analysis of the *NNT* gene**

122 Genomic DNA was extracted from EDTA-preserved whole blood using the Nucleon BACC3 kit (GE  
123 healthcare, Chalfont Saint Giles, Buckinghamshire, UK). Sanger sequencing was done for 47 patients  
124 and massive parallel sequencing (MPS) for three (patients 11, 12 and 13 in Table 1).

### 125 ***Sanger sequencing***

126 Selective amplification of the 21 coding exons of the *NNT* gene was performed in twenty fragments by  
127 PCR using specific primers (available on request). Conventional dideoxy sequencing of exons and  
128 exon-intron boundaries was done using Big-Dye Terminators. Sequencing products were loaded on an  
129 ABI-3730XL and analyzed using SeqScape software v2.5 (Life Technologies, CA, USA). Sequence  
130 variants were designated according to the Human Genome Society recommendations  
131 ([www.hgvs.org/rec.html](http://www.hgvs.org/rec.html)) using the NCBI reference sequences NC\_000005.9, NM\_012343.3 and  
132 NP\_036475 built on the GRCh37/hg19.

### 133 ***Massive parallel sequencing (MPS) or next generation sequencing (NGS)***

134 DNAs were tested using an amplicon-based library preparation. A custom panel targeting 57 genes,  
135 involved in adrenal insufficiency and disorders of sex development, including *NNT*, was designed  
136 using Ion AmpliSeq designer software (Life Technologies) (coding regions  $\pm$  50bp) (article underway,  
137 list available on request). The library preparation was done according to the manufacturer's  
138 instructions with the Ion AmpliSeq Library Kit v2.0 (Life Technologies). Enrichment and  
139 quantification of target DNA were validated on the Caliper LabChip-GX using the high sensitivity

140 assay kit (Caliper LifeSciences Waltham, MA, USA). The patients were barcoded and pooled by  
141 groups of eight to get a sufficient depth of coverage (>100X) at sequencing. For the sequencing step,  
142 enriched template-positive Ion PGM spheres were prepared by emulsion PCR with the Ion OneTouch  
143 2 System (Life Technologies). The resulting live Ion Sphere Particles (ISPs) were loaded on an Ion  
144 316 Chip. Sequencing was done on the Ion Torrent Personal Genome Machine (PGM) with the PGM  
145 Sequencing 200 Kit. The bioinformatics pipeline used was the Torrent Suite software implemented  
146 with the sequencer and with the default parameters. *NNT* mutations were validated by Sanger  
147 sequencing.

#### 148 ***Array comparative genomic hybridization (aCGH) and long range PCR***

149 To confirm a deletion, aCGH or chromosomal microarray (CMA) was performed according to the  
150 manufacturer's instructions, using the Agilent SurePrint G3 Human CGH Microarray 4x180K  
151 AMADID 022060 (Agilent Technologies, Inc, Santa Clara, CA). This was followed by long-range  
152 PCR using the Qiagen LongRange PCR kit (Qiagen, Hilden, Germany) according to the supplier's  
153 recommendations. Conventional dideoxy sequencing of the PCR product was done as described in the  
154 paragraph "Sanger sequencing" (primers available on request).

#### 155 **Pathogenicity prediction**

##### 156 ***Multiple sequence alignment***

157 Multiple sequence alignment of *NNT* protein sequences from different species was used to analyze  
158 structurally conserved regions and to predict putative effects of missense mutations. The sequences  
159 were found in the Uniprot database (<http://www.uniprot.org/>), aligned with ClustalW  
160 (<http://www.ebi.ac.uk/Tools/msa/clustalw2/>) using default parameters, displayed and then edited using  
161 Genedoc (<http://www.psc.edu/index.php/user-resources/software/genedoc>).

##### 162 ***Software and databases***

163 For each new missense mutation, pathogenicity was predicted *in silico* using several programs: align  
164 GVGD, Polyphen 2, SIFT and Mutation taster. The Grantham score was calculated to predict the  
165 effect of substitutions between amino acids. This score looks at chemical properties to define a score  
166 range between 0 and 215. Higher scores indicate greater differences in the chemical properties  
167 between two amino acids (i.e., polarity and molecular volume) and may indicate a stronger (negative)



168 effect on protein structure and function. The dbSNP, EVS and ExAC browser databases were searched  
169 to determine if variants had already been reported.  
170

Accepted manuscript

171 **RESULTS**172 **NNT gene sequencing**

173 Ten different *NNT* mutations, scattered throughout the gene, were found in thirteen families (eighteen  
174 patients) (**Table 1, Figure 2**). Seven of them were new mutations: two nonsense (p.Arg129\*,  
175 p.Arg379\*), two missense (p.Met337Val, p.Ala863Glu), two frameshift (p.Val665Profs\*29,  
176 p.Ala704Serfs\*19), and one start loss (c.3G>A (p.Met1?)). The p.Arg129\* mutation was found in four  
177 families, all of Algerian origin (**Table 2**). Consanguinity was present in eight of the thirteen families  
178 and homozygous mutations were found in eleven families. No consanguinity was found in the other  
179 homozygous families (1, 5 and 10), but the parents in family 10 were from the same small village in  
180 France. The patients of families 4 and 12 were compound heterozygotes. Patient 12 was first thought  
181 homozygous for the mutation p.Arg71\*. However, the mother did not carry the mutation and thus a  
182 deletion was suspected and thereafter confirmed by aCGH analysis and long range PCR sequenced  
183 step by step. For the three patients studied by MPS, all variants found in other genes were benign.

184 **Pathogenicity prediction (Table 1)**

185 The p.Pro437Leu and p.Arg71\* mutations have already been described<sup>9, 15</sup>. For the frameshift or  
186 nonsense mutations, the consequences should be premature truncated proteins or an absence of protein  
187 due to intervention of the nonsense-mediated decay system. The new mutation, c.3G>A (p.Met1?),  
188 affecting the translation initiation site, should switch this latter to an in-frame downstream methionine  
189 at codon 192. In the absence of its N-terminal part, the resulting NNT should be non-functional.

190 To predict the pathogenicity of missense mutations, multiple alignments of NNT proteins were done in  
191 order to locate the changed residue in the protein structure and identify conservation between species  
192 <sup>18, 27</sup> (**Figure 3**).

193 The p.Ala863Glu mutation is located in the transmembrane helix 14 (H14) of domain II and is highly  
194 conserved between species (**Figure 3**). H14 appears to indirectly facilitate proton translocation by  
195 influencing the centrally-located H9, H10, and H13, in which the proton channel is assumed to be  
196 located. In *Escherichia coli*, mutations of certain residues in these regions result in intermediate  
197 inhibitory effects <sup>28</sup>. This mutation may disrupt the conformational changes responsible for  
198 interconversion of the open and occluded states <sup>29</sup>. It may also play a role in coupling between the

199 redox state of the nucleotide and the proton movement in the protein, as it is near the NADP(H)  
200 binding domain. In *in silico* predictions, this mutation was most likely pathogenic using Align-GVGD  
201 class, probably damaging using Polyphen-2, deleterious using SIFT and disease causing using  
202 Mutation Taster. The high Grantham score of 107 is also concordant. This mutation is not reported in  
203 dbSNP, EVS or ExAC browser databases and has not been found in one hundred French Caucasian  
204 healthy controls. As expected, the parents of patient 7 were heterozygous as were his two healthy  
205 brothers.

206 The missense mutation, p.Met337Val, was identified in the NAD(H) binding domain near the  
207 NAD(H) binding site. It should inhibit the hydride transfer from NADH to NADP<sup>+</sup>. The residue is  
208 highly conserved between species (**Figure 3**). The mutation was predicted to be deleterious by all of  
209 the mutation prediction tools mentioned above, despite a Grantham score of 21. This variation was not  
210 listed in the databases (dbSNP, EVS or ExAC browser) and not found in one hundred healthy controls  
211 from the Maghreb.

#### 212 **Clinical data at onset and follow-up (Table 2)**

213 Table 2 presents the clinical data and follow up for the eighteen patients reported. Only the  
214 predominant features are presented in the text.

#### 215 ***Clinical presentation at age of diagnosis***

216 Severe hypoglycemia, sometimes leading to coma, was the main symptom at age of diagnosis in all  
217 but two patients (numbers 11a and 12). That symptom was often associated with infections and  
218 melanoderma. This latter, upon inquiry, was often reported to have been present before the  
219 hypoglycemia. Five out of the thirteen families had experienced multiple deaths of other children;  
220 although not diagnosed at the time, those deaths too were probably due to adrenal insufficiency and  
221 severe hypoglycemia. Patient 11a and 12 experienced salt wasting (SW) at onset without  
222 hypoglycemia and three other patients had a global adrenal insufficiency (patients 2b, 6, 8) with SW.  
223 The median age at onset in our cohort was 11.5 months (min-max: 1.5 months-4 years) (**Table 2,**  
224 **Figure 4A**). Most cases were diagnosed belatedly around the first year of life (8-18 months) but some  
225 involving stress conditions were diagnosed earlier. A difference in age at onset was detected between  
226 the subgroup with isolated glucocorticoid deficiency and that with global adrenal insufficiency. This

227 was the case for both our cohort alone (Kruskal-Wallis test: p-value =0.03379, **Figure 4B**) and our  
228 cohort aggregated with the data available in the literature (Kruskal-Wallis test: p-value =0.003705,  
229 **Figure 4 C**). However, no difference in age at onset was found between the subgroup homozygous for  
230 non-truncated mutations and that homozygous for truncated mutations (Kruskal-Wallis test: p-value  
231 =0.2172).

### 232 *Follow-up*

233 At study end, the age of the 16 patients ranged from 4 to 57 years old, permitting a long patient  
234 follow-up.

235 - Mineralocorticoid function:

236 • Patient 3 had SW at age 15 then recurrence at 18, illustrating the importance of  
237 follow-up. Moreover, eight other patients (1, 2a, 4a-b, 10a-c, 13) had elevated renin  
238 and/or low aldosterone and needed mineralocorticoid or salt therapy.

239 - Gonadotropic/genitalia function:

240 • Patients 11a and 11b, both presented with cryptorchidism and underwent surgery for  
241 ectopic testes.

242 • Two patients (7 and 9) had precocious puberty at age five, associated with testicular  
243 nodules, low or undetectable gonadotropins and high testosterone. Patient 9 had  
244 surgery revealing an interstitial Leydig cell adenoma. In this patient, a short GnRH  
245 analog therapy was discontinued and the adenoma removed. Thereafter, testosterone  
246 remained at pre-pubertal values.

247 • For patient 12, testicular inclusions were detected at age 18 during imaging studies for  
248 azoospermia and were consistent with testicular adrenal rest tumor (TART). His  
249 azoospermia was associated with elevated FSH (LH: 9 mUI/ml, FSH: 18 mUI/ml) but  
250 normal testosterone (5.8 nmol/L). His karyotype was normal (46,XY) with no Y  
251 chromosome microdeletion. Increasing the dose of his glucocorticoid replacement  
252 therapy did not reduce the testicular inclusion and had no effect on spermatogenesis.

253 • Patient 1 had a testicular biopsy at age 31 for a left varicocele with epididymitis.

254 - Heart function:

255 • A transthoracic echocardiography in patient 1, at age 23 showed a typical and severe  
256 asymmetrical left ventricular hypertrophy (maximal wall thickness measured at the  
257 basilar septum: 36 mm). The resting left ventricular outflow gradient was measured at  
258 15 mmHg. There was no mitral regurgitation. The left atrium was dilated (25 mm<sup>2</sup>).  
259 Patient 9 at age six had normal heart function but with a left ventricular ejection  
260 fraction of 75%.

261 - Other functions:

- 262 • Two patients (2b and 9) had hypothyroidism with a thyroid gland in place. Patient 2b  
263 had congenital hypothyroidism and patient 9 hypothyroidism with low free T4 at age  
264 five and elevated TSH with no goiter at age seven.
- 265 • Three patients had recurrent urinary tract infections (4b, 11a, 13).
- 266 • We did not have information on social aspects for all the patients but four of them  
267 (patients 3, 5, 7 and 9) were experiencing poor academic performance or acquisition  
268 delays, possibly due to severe hypoglycemia.
- 269 • None of the patients presented pancreatic dysfunction or impaired glucose tolerance.  
270 There were no growth disorders for patients who reached adult age.

271

272 **DISCUSSION**

273 Here, we report seven new *NNT* mutations identified in eighteen patients, eleven with FGD and seven  
274 with global adrenal insufficiency, who were members of thirteen families, i.e., 26% of the fifty  
275 families studied.

276 The mutations were distributed throughout the gene and most led to a premature truncated protein or  
277 an absence of protein. The most frequent mutation found in our cohort was p.Arg129\*, which was  
278 identified in four Algerian families, suggesting the possibility of a founder mutation similar to  
279 p.Gly200Ser in Palestine <sup>12</sup>. We also identified two novel missense mutations, which should be  
280 pathogenic. Our patients with *NNT* mutations displayed a severe phenotype, with adrenal  
281 insufficiency often revealed by hypoglycemic convulsions. Most of the cases were diagnosed  
282 belatedly, around the first year of life (8-18 months). Some however were discovered earlier if stress  
283 conditions had occurred, i.e., intercurrent infections, suggesting the need of a stress to trigger the  
284 disease (**Figure 4A**). This is in accordance with the literature where the minimum age at diagnosis is  
285 three days <sup>12</sup> and the median age at onset is 12 months for the 29 patients for whom data are available  
286 <sup>9, 11-13, 15, 16</sup>. Unlike those of Jazayeri *et al*, our data suggest earlier onset in patients with global adrenal  
287 deficiency compared to those with isolated glucocorticoid deficiency (**Figure 4B and C**). The  
288 phenotypic variability between patients having a same mutation or within a same family (family 2),  
289 suggests that there is no correlation between genotype and phenotype.

290 It is clear that *NNT* mutations can result in global adrenal deficiency. In the literature and comparably  
291 to fourteen of our patients, five families were recently described with mineralocorticoid deficiency  
292 present at onset and three others with elevated renin or electrolytes imbalance <sup>11-13, 16</sup>. Our patient 3 had  
293 salt wasting at age 15, although aldosterone requirements normally decrease throughout life <sup>30</sup>. We  
294 observed phenotypic heterogeneity even within a same family. Patient 11a presented salt wasting  
295 whereas patient 11b had no mineralocorticoid deficiency. This emphasizes the need for careful  
296 monitoring of this function, since some patients classified as FGD may also have a slight  
297 mineralocorticoid defect. It has been shown that C57BL6/J mice carrying *NNT* mutations have  
298 disorganized zonae fasciculata with higher levels of apoptosis <sup>9</sup>. As aldosterone requirement decreases

299 through life, the mineralocorticoid defect may be the consequence of extended damage to all adrenal  
300 zona.

301 NNT has a role in the oxidative stress response and mutations in it may thus affect all tissues rich in  
302 mitochondria. For this reason too, patients with NNT mutations need to be closely monitored. Two *in*  
303 *vitro* studies on the fibroblasts<sup>12</sup> and lymphocyte mitochondria<sup>31</sup> of patients homozygous for missense  
304 *NNT* mutations showed an increase in ROS levels, a decrease of ATP content, and impaired  
305 morphology of mitochondria with reduced mitochondrial mass and increased mtDNA deletion due to a  
306 lack of thymidylate biosynthesis<sup>12,31</sup>. The results from those two studies suggest that all tissues can be  
307 injured, as do our results from the follow-up of patients with extra-adrenal defects.

308 Although NNT is widely expressed in adrenal, heart, kidney, thyroid and adipose tissues, the most  
309 affected tissue in our cohort appeared to be the gonads<sup>9</sup>. Two of our patients had cryptorchidism  
310 (patients 11a and b) and two others (7 and 9) presented similar histories involving, both at about five  
311 years of age, the development of palpable nodules on the testicular surface or testicular enlargement  
312 followed by the onset of puberty with high testosterone levels. These last two cases are comparable to  
313 that reported by Hershkovitz *et al*<sup>13</sup>. For our patients 7 and 9, gonadotropins were in the normal pre-  
314 pubertal range and the increase in testosterone seemed to be due to secretion by autonomous nodules  
315 responsible for the onset of puberty. Since the regression of puberty for patient 9 was due either to the  
316 removal of the adenoma or the short GnRH analog treatment, we cannot pronounce as to the central,  
317 peripheral or mixed origin of the precocious puberty. Reporting on a boy with a mutation in *DAX-*  
318 *1/NR0B1*, Domenice *et al* concluded that chronic excessive ACTH levels may stimulate Leydig cells  
319 and lead to gonadotropin-independent precocious puberty<sup>32</sup>, a view toward which Hershkovitz *et al*'s  
320 case<sup>13</sup> argues as well. In contrast, the testicular inclusions of our patient 12, associated with  
321 azoospermia but normal testosterone values at age 18, although not reduced by glucocorticoid therapy,  
322 should be TART, often found in congenital adrenal hyperplasia<sup>33</sup>.

323 To date, we have observed heart function impairment (progressive hypertrophic cardiomyopathy) in  
324 only one of our patients but cannot exclude future cases because of the mean age of our cohort and the  
325 subnormal imaging of patient 9. This underlines the specific role of NNT in heart tissue. In *B6J-Sod2-*  
326 */-* mice, the presence of a normal *NNT* allele preserves cardiac function, delays the onset of heart

327 failure, and extends survival to the end of gestation<sup>24</sup>. In comparison, the suppression of *NNT* in  
328 zebrafish results in ventricular malformations and contractile dysfunctions<sup>34</sup>. Moreover, in humans,  
329 relationships between decreased NNT activity, modified mitochondrial redox regulation and cardiac  
330 failure have been reported. In the failing human heart, a partial loss of NNT activity adversely affects  
331 NADPH-dependent enzymes and the capacity to maintain membrane potential. This contributes to a  
332 decline in bioenergetic capacity, redox regulation and antioxidant defense, exacerbating oxidative  
333 damage to cellular proteins<sup>26</sup>. A recent report of a heterozygous frameshift mutation of *NNT* in  
334 humans with left ventricular noncompaction supports the assumption that NNT plays a major role in  
335 myocardium<sup>34</sup>. However, Nickel *et al* demonstrated a completely opposing view. They reported that  
336 during heart pressure overload, NNT adopts a reverse mode contributing to oxidative stress from  
337 which mice with mutation in *NNT* are protected<sup>35</sup>. Those puzzling new insights may suggest that the  
338 functional mode (forward or reverse) of NNT is dependent on the metabolic state. Nevertheless,  
339 *TXNRD2* is in the same pathway of ROS detoxification and *TXNRD2* heterozygous mutations in  
340 humans have also been linked to dilated cardiomyopathy. Thus, for now, cardiac follow-up should be  
341 done<sup>10,36</sup>.

342 The thyroid gland, highly exposed to oxidative stress, was the third most-affected organ in our cohort.  
343 Beyond our two patients with hypothyroidism, probably due to some hormone synthesis defect, two  
344 other cases with subclinical hypothyroidism have been reported<sup>16</sup>. The biosynthesis of thyroid  
345 hormones (TH) is an oxidative biochemical reaction that depends on the formation of peroxide.  
346 However, two studies have suggested that when thyroid cells are exposed to significant amount of  
347 ROS, thyroid peroxidase and iodide organification are inhibited<sup>37, 38</sup>. Another argument is the  
348 prevalence of thyroid dysfunction in patients with Down syndrome who are under unusual increased  
349 oxidative stress<sup>39</sup>. NNT mutations may disturb the balance between H<sub>2</sub>O<sub>2</sub> produced for TH  
350 biosynthesis and anti-oxidants to protect cells from H<sub>2</sub>O<sub>2</sub> mediated oxidative damages, thus leading to  
351 TH formation inhibition. Nevertheless, our patients with hypothyroidism were consanguineous and we  
352 cannot exclude that another gene involved in the thyroid may be mutated.

353 Other functions in our patients were normal, especially growth and glucose metabolism. Glucose  
354 intolerance or diabetes in humans has not been reported in the setting of NNT mutation, although



355 defects in mitochondrial energy metabolism have also been implicated in diabetes. This contrasts with  
356 the impaired insulin secretion observed in *NNT* mutant mice for which only the  $\beta$ -cells seemed  
357 sensitive<sup>40</sup>. Increased ROS usually plays a role in innate immunity against bacterial cyto-invasion<sup>41</sup>.  
358 Despite that, three of our patients experienced recurrent urinary tract infections. We thus feel that  
359 additional studies are necessary to further investigate renal function.

360 In conclusion, we report here mutations in the *NNT* gene, which was one of the most frequent  
361 molecular etiologies in our “atypical” congenital adrenal insufficiency cohort. Deducing from our  
362 results and those of other authors, mutations in *NNT* should be searched not only in FGD but also in  
363 global adrenal insufficiency. Above all, careful follow-up, especially for mineralocorticoid, puberty,  
364 fertility, heart and thyroid function, must be maintained for all patients. The MPS approach described  
365 in the methods section, with a large panel of genes including *NNT*, appears to be ~~the most~~ efficient for  
366 genetic diagnosis<sup>16, 42</sup>. The analysis of more than one gene at a time is a powerful way to reach a  
367 diagnosis in diseases with phenotype heterogeneity. We note that more and more “atypical” cases of  
368 PAI are being described, for example STAR and CYP11A1 mutations in boys with PAI with or  
369 without DSD.

## 370 **DISCLOSURE**

### 371 **Declaration of interest**

372 The authors declare that there are no conflicts of interest that could prejudice the impartiality of the  
373 research reported.

### 374 **Funding**

375 This research did not receive any specific grant from any funding agency in the public, commercial or  
376 not-for-profit sectors.

## 377 **REFERENCES**

- 378 1. Shepard TH, Landing BH & Mason DG. Familial Addison's disease; case reports of two  
379 sisters with corticoid deficiency unassociated with hypoaldosteronism. *AMA J Dis Child* 1959  
380 **97** 154-162.
- 381 2. Allgrove J, Clayden GS, Grant DB & Macaulay JC. Familial glucocorticoid deficiency with  
382 achalasia of the cardia and deficient tear production. *Lancet* 1978 **1** 1284-1286.

- 383 3. Clark AJ, McLoughlin L & Grossman A. Familial glucocorticoid deficiency associated with  
384 point mutation in the adrenocorticotropin receptor. *Lancet* 1993 **341** 461-462.
- 385 4. Metherell LA, Chapple JP, Cooray S, David A, Becker C, Ruschendorf F, Naville D, Begeot  
386 M, Khoo B, Nurnberg P, *et al.* Mutations in MRAP, encoding a new interacting partner of the  
387 ACTH receptor, cause familial glucocorticoid deficiency type 2. *Nat Genet* 2005 **37** 166-170.
- 388 5. Metherell LA, Naville D, Halaby G, Begeot M, Huebner A, Nurnberg G, Nurnberg P, Green J,  
389 Tomlinson JW, Krone NP, *et al.* Nonclassic lipid congenital adrenal hyperplasia  
390 masquerading as familial glucocorticoid deficiency. *J Clin Endocrinol Metab* 2009 **94** 3865-  
391 3871.
- 392 6. Parajes S, Kamrath C, Rose IT, Taylor AE, Mooij CF, Dhir V, Grotzinger J, Arlt W & Krone  
393 N. A novel entity of clinically isolated adrenal insufficiency caused by a partially inactivating  
394 mutation of the gene encoding for P450 side chain cleavage enzyme (CYP11A1). *J Clin*  
395 *Endocrinol Metab* 2011 **96** E1798-1806.
- 396 7. Sahakitrungruang T, Tee MK, Blackett PR & Miller WL. Partial defect in the cholesterol side-  
397 chain cleavage enzyme P450scc (CYP11A1) resembling nonclassic congenital lipid adrenal  
398 hyperplasia. *J Clin Endocrinol Metab* 2010 **96** 792-798.
- 399 8. Hughes CR, Guasti L, Meimaridou E, Chuang CH, Schimenti JC, King PJ, Costigan C, Clark  
400 AJ & Metherell LA. MCM4 mutation causes adrenal failure, short stature, and natural killer  
401 cell deficiency in humans. *J Clin Invest* 2012 **122** 814-820.
- 402 9. Meimaridou E, Kowalczyk J, Guasti L, Hughes CR, Wagner F, Frommolt P, Nurnberg P,  
403 Mann NP, Banerjee R, Saka HN, *et al.* Mutations in NNT encoding nicotinamide nucleotide  
404 transhydrogenase cause familial glucocorticoid deficiency. *Nat Genet* 2012 **44** 740-742.
- 405 10. Prasad R, Chan LF, Hughes CR, Kaski JP, Kowalczyk JC, Savage MO, Peters CJ, Nathwani  
406 N, Clark AJ, Storr HL, *et al.* Thioredoxin Reductase 2 (TXNRD2) mutation associated with  
407 familial glucocorticoid deficiency (FGD). *J Clin Endocrinol Metab* 2014 **99** E1556-1563.
- 408 11. Yamaguchi R, Kato F, Hasegawa T, Katsumata N, Fukami M, Matsui T, Nagasaki K & Ogata  
409 T. A novel homozygous mutation of the nicotinamide nucleotide transhydrogenase gene in a  
410 Japanese patient with familial glucocorticoid deficiency. *Endocr J* 2013 **60** 855-859.

- 411 12. Weinberg-Shukron A, Abu-Libdeh A, Zhadeh F, Carmel L, Kogot-Levin A, Kamal L, Kanaan  
412 M, Zeligson S, Renbaum P, Levy-Lahad E, *et al.* Combined mineralocorticoid and  
413 glucocorticoid deficiency is caused by a novel founder nicotinamide nucleotide  
414 transhydrogenase mutation that alters mitochondrial morphology and increases oxidative  
415 stress. *J Med Genet* 2015.
- 416 13. Hershkovitz E, Arafat M, Loewenthal N, Haim A & Parvari R. Combined adrenal failure and  
417 testicular adrenal rest tumor in a patient with nicotinamide nucleotide transhydrogenase  
418 deficiency. *J Pediatr Endocrinol Metab* 2015 **28** 1187-1190.
- 419 14. Jazayeri O, Liu X, van Diemen CC, Bakker-van Waarde WM, Sikkema-Raddatz B, Sinke RJ,  
420 Zhang J & van Ravenswaaij-Arts CM. A novel homozygous insertion and review of published  
421 mutations in the NNT gene causing familial glucocorticoid deficiency (FGD). *Eur J Med*  
422 *Genet* 2015 **58** 642-649.
- 423 15. Novoselova TV, Rath SR, Carpenter K, Pachter N, Dickinson JE, Price G, Chan LF, Choong  
424 CS & Metherell LA. NNT pseudoexon activation as a novel mechanism for disease in two  
425 siblings with familial glucocorticoid deficiency. *J Clin Endocrinol Metab* 2015 **100** E350-354.
- 426 16. Guran T, Buonocore F, Saka N, Nuri Ozbek M, Aycan Z, Bereket A, Bas F, Darcan S, Bideci  
427 A, Guven A, *et al.* Rare causes of primary adrenal insufficiency: Genetic and clinical  
428 characterization of a large nationwide cohort. *J Clin Endocrinol Metab* 2015 jc20153250.
- 429 17. Hatefi Y & Yamaguchi M. Nicotinamide nucleotide transhydrogenase: a model for utilization  
430 of substrate binding energy for proton translocation. *FASEB J* 1996 **10** 444-452.
- 431 18. Arkblad EL, Betsholtz C, Mandoli D & Rydstrom J. Characterization of a nicotinamide  
432 nucleotide transhydrogenase gene from the green alga *Acetabularia acetabulum* and  
433 comparison of its structure with those of the corresponding genes in mouse and  
434 *Caenorhabditis elegans*. *Biochim Biophys Acta* 2001 **1520** 115-123.
- 435 19. Hoek JB & Rydstrom J. Physiological roles of nicotinamide nucleotide transhydrogenase.  
436 *Biochem J* 1988 **254** 1-10.
- 437 20. Arkblad EL, Tuck S, Pestov NB, Dmitriev RI, Kostina MB, Stenvall J, Tranberg M &  
438 Rydstrom J. A *Caenorhabditis elegans* mutant lacking functional nicotinamide nucleotide

- 439 transhydrogenase displays increased sensitivity to oxidative stress. *Free Radic Biol Med* 2005  
440 **38** 1518-1525.
- 441 21. Huang TT, Naeemuddin M, Elchuri S, Yamaguchi M, Kozy HM, Carlson EJ & Epstein CJ.  
442 Genetic modifiers of the phenotype of mice deficient in mitochondrial superoxide dismutase.  
443 *Hum Mol Genet* 2006 **15** 1187-1194.
- 444 22. Miller WL. Steroid hormone synthesis in mitochondria. *Mol Cell Endocrinol* 2013 **379** 62-73.
- 445 23. Freeman H, Shimomura K, Horner E, Cox RD & Ashcroft FM. Nicotinamide nucleotide  
446 transhydrogenase: a key role in insulin secretion. *Cell Metab* 2006 **3** 35-45.
- 447 24. Kim A, Chen CH, Ursell P & Huang TT. Genetic modifier of mitochondrial superoxide  
448 dismutase-deficient mice delays heart failure and prolongs survival. *Mamm Genome* 2010 **21**  
449 534-542.
- 450 25. Prasad R, Kowalczyk JC, Meimaridou E, Storr HL & Metherell LA. Oxidative stress and  
451 adrenocortical insufficiency. *J Endocrinol* 2014 **221** R63-73.
- 452 26. Sheeran FL, Rydstrom J, Shakhparonov MI, Pestov NB & Pepe S. Diminished NADPH  
453 transhydrogenase activity and mitochondrial redox regulation in human failing myocardium.  
454 *Biochim Biophys Acta* 2010 **1797** 1138-1148.
- 455 27. Olausson T, Fjellstrom O, Mueller J & Rydstrom J. Molecular biology of nicotinamide  
456 nucleotide transhydrogenase--a unique proton pump. *Biochim Biophys Acta* 1995 **1231** 1-19.
- 457 28. Karlsson J, Althage M & Rydstrom J. Roles of individual amino acids in helix 14 of the  
458 membrane domain of proton-translocating transhydrogenase from *Escherichia coli* as deduced  
459 from cysteine mutagenesis. *Biochemistry* 2003 **42** 6575-6581.
- 460 29. Jackson JB. A review of the binding-change mechanism for proton-translocating  
461 transhydrogenase. *Biochim Biophys Acta* 2012.
- 462 30. Rosler A. The natural history of salt-wasting disorders of adrenal and renal origin. *J Clin*  
463 *Endocrinol Metab* 1984 **59** 689-700.
- 464 31. Fujisawa Y, Napoli E, Wong S, Song G, Yamaguchi R, Matsui T, Nagasaki K, Ogata T &  
465 Giulivi C. Impact of a novel homozygous mutation in nicotinamide nucleotide

- 466 transhydrogenase on mitochondrial DNA integrity in a case of familial glucocorticoid  
467 deficiency. *BBA Clin* 2015 **3** 70-78.
- 468 32. Domenice S, Latronico AC, Brito VN, Arnhold IJ, Kok F & Mendonca BB.  
469 Adrenocorticotropin-dependent precocious puberty of testicular origin in a boy with X-linked  
470 adrenal hypoplasia congenita due to a novel mutation in the DAX1 gene. *J Clin Endocrinol*  
471 *Metab* 2001 **86** 4068-4071.
- 472 33. Pierre P, Despert F, Tranquart F, Coutant R, Tardy V, Kerlan V, Sonnet E, Baron S, Lorey Y,  
473 Emy P, *et al.* Adrenal rest tissue in gonads of patients with classical congenital adrenal  
474 hyperplasia: multicenter study of 45 French male patients. *Ann Endocrinol (Paris)* 2012 **73**  
475 515-522.
- 476 34. Bainbridge MN, Davis EE, Choi WY, Dickson A, Martinez HR, Wang M, Dinh H, Muzny D,  
477 Pignatelli R, Katsanis N, *et al.* Loss of Function Mutations in NNT Are Associated with Left  
478 Ventricular Noncompaction. *Circ Cardiovasc Genet* 2015.
- 479 35. Nickel AG, von Hardenberg A, Hohl M, Loffler JR, Kohlhaas M, Becker J, Reil JC, Kazakov  
480 A, Bonnekoh J, Stadelmaier M, *et al.* Reversal of Mitochondrial Transhydrogenase Causes  
481 Oxidative Stress in Heart Failure. *Cell Metab* 2015 **22** 472-484.
- 482 36. Sibbing D, Pfeufer A, Perisic T, Mannes AM, Fritz-Wolf K, Unwin S, Sinner MF, Gieger C,  
483 Gloeckner CJ, Wichmann HE, *et al.* Mutations in the mitochondrial thioredoxin reductase  
484 gene TXNRD2 cause dilated cardiomyopathy. *Eur Heart J* 2011 **32** 1121-1133.
- 485 37. Nadolnik LI, Niatetskaya ZV & Lupachyk SV. Effect of oxidative stress on rat thyrocyte  
486 iodide metabolism. *Cell Biochem Funct* 2008 **26** 366-373.
- 487 38. Sugawara M, Sugawara Y, Wen K & Giulivi C. Generation of oxygen free radicals in thyroid  
488 cells and inhibition of thyroid peroxidase. *Exp Biol Med (Maywood)* 2002 **227** 141-146.
- 489 39. Campos C & Casado A. Oxidative stress, thyroid dysfunction & Down syndrome. *Indian J*  
490 *Med Res* 2015 **142** 113-119.
- 491 40. Freeman HC, Hugill A, Dear NT, Ashcroft FM & Cox RD. Deletion of nicotinamide  
492 nucleotide transhydrogenase: a new quantitative trait locus accounting for glucose intolerance in  
493 C57BL/6J mice. *Diabetes* 2006 **55** 2153-2156.

- 494 41. Lu H, Wu Q & Yang H. DUOX2 promotes the elimination of the *Klebsiella pneumoniae*  
495 strain K5 from T24 cells through the reactive oxygen species pathway. *Int J Mol Med* 2015 **36**  
496 551-558.
- 497 42. Chan LF, Campbell DC, Novoselova TV, Clark AJ & Metherell LA. Whole-Exome  
498 Sequencing in the Differential Diagnosis of Primary Adrenal Insufficiency in Children. *Front*  
499 *Endocrinol (Lausanne)* 2015 **6** 113.
- 500  
501

Accepted manuscript

502 **TABLE AND FIGURES LEGENDS**

503 **Table 1:** NNT mutations in thirteen families with PAI. d: domain, TMH: transmembrane helix, -:  
504 not applicable, NMD: nonsense-mediated decay

505

506 **Table 2:** Clinical characteristics and follow-up of the patients with NNT mutations. -: not determined,  
507 M: male, F: female, NI: normal, \*: deceased, yrs: age in years, ttt: treatment, MC: mineralocorticoid,  
508 GC: glucocorticoid, SW: salt wasting, ∨: decreased ↗: increased, LVEF: left ventricular fraction,  
509 ENT: ear, nose, throat. Major abnormalities are in bold. For two patients (4a and 9) the age of  
510 diagnosis was late despite an earlier onset.

511

512 **Figure 1:** Role of NNT in free radical metabolism in the mitochondria ETC: electron transport chain  
513 GSSG: glutathione disulfide; GSH: glutathione; GPX: glutathione peroxidase; GR: glutathione  
514 reductase; TXNRD2: thioredoxin reductase; PRDX3: peroxiredoxin 3

515

516 **Figure 2:** NNT Mutations. Comparison between the domain structure of NNT protein and *NNT* exons  
517 in humans. Above: nonsense or frameshift mutations; below: missense mutations. New mutations  
518 indicated by rectangles. Underlined mutation is probably a splicing mutation.

519 .

520 **Figure 3:** Partial multiple amino acid alignment of NNT in human, bovine, mouse, *Caenorhabditis*  
521 *elegans*, *Escherichia coli* and *Acetabularia acetubulum*. Alignment was performed in clustalW and  
522 edited with Genedoc. The mutant residues p.M337V and p.A863E and corresponding amino acids are  
523 shaded and show the conservation across all species.

524

525 **Figure 4: A.** Age at presentation for the patients of our cohort GD: glucocorticoid deficiency, SW: salt  
526 wasting. **B&C.** Difference in age at presentation (Kruskal-Wallis test, \*: significance at p<0.05)  
527 between the group of patients with glucocorticoid deficiency and the group with salt wasting +/-

528 glucocorticoid deficiency within our cohort (p-value =0.03379\*) (**B**); our data aggregated with the  
529 data available in the literature (p-value =0.003705\*) (**C**).

Accepted manuscript



Table 1 : NNT mutations in thirteen families with PAI

Nucleotide change (NM_012343.3)	Exon	Protein change (NP_036475)	Protein consequence	Domain	Predictive software				dbSNP ID	Allele count		Family number	Ref.
					GVGD	SIFT	Polyphen 2	Mutation Taster		ESP	ExAC		
c.3G>A	2	p.M1?	Start loss	Pre-sequence					-	0/13006	0/121286		9,14
c.211 C>T	3	p.R71*	Premature truncation at amino acid 71. NMD?	dI					-	0/13006	0/121286	1,4,12	15
c.385 C>T	4	p.R129*	Premature truncation at amino acid 129. NMD?	dI					-	0/13002	0/121286	2,3,4,11	
c.1009A>G	8	p.M337V	Missense mutation at amino acid 337 in the -DH binding domain protein	dI	less likely	Deleterious	Probably damaging	Disease causing	-	0/13006	0/121286	13	
c.1135C>T	9	p.R379*	Premature truncation at amino acid 379. NMD?	dI					-	0/13006	0/121286	9	
c.1310C>T	10	p.P437L	Missense mutation at amino acid 437 Role in dI-dII/dIII communication	dI	less likely	Deleterious	Probably damaging	Disease causing	-	0/13006	1/120146	10	9
c.1992_2005del	14	p.V665Pfs*29	Frameshift: premature truncation at amino acid 694	dII TMH7					-	0/13006	0/121286	5	
c.2106_2109dup	15	p.A704Sfs*19	Frameshift: premature truncation at amino acid 723	dII TMH9					-	0/13006	0/121286	6	
c.2588C>A	17	p.A863E	Missense mutation at amino acid 863 in the transmembrane domain (helix 14)	dII TMH14	Most Likely	Deleterious	Probably damaging	Disease causing	-	0/13006	0/121286	7	
c.(-51+1_-53-1)_(381+1_382-1)del	2-3	p.0?	Start loss. Absence of protein								0/121286	12	

d:domain, TMH: transmembrane helix, -: not applicable, NMD nonsense-mediated decay

Table 2: Clinical characteristics and follow-up of the patients with *NNT* mutations.

Family	Origin	Consanguinity	NNT mutation NP_036475	Sex	Age (yrs)	Age at diagnosis (months or yrs where indicated)	Clinical data at age of diagnosis	Mineralocorticoid defect	Gonads	Heart	Thyroid	Related death
1	French	no	p.R71*/p.R71*	M	43	14	hypoglycemia, melanoderma	thirst for salt, MC ttt (↑renin)	onset of puberty at 12 yrs, NI testicular function, <b>surgery for varicocele</b>	<b>hypertrophic cardiomyopathy</b>	NI	brother at 2 yrs
2a	Algerian	yes	p.R129*/p.R129*	M	32	6	hypoglycemic convulsions, delay of diagnosis due to GC therapy for asthma	MC ttt at 3 yrs (↑renin)	onset of puberty at 13 yrs 9 months	-	NI	
2b				M	15	3	hypoglycemic convulsions, <b>SW</b>	MC ttt, SW at 12 yrs after an attempt to stop MC ttt	onset of puberty at 12 yrs, low testosterone at 15 yrs	NI imaging (12 yrs)	<b>congenital hypothyroidism</b> with thyroid gland in place	sister at 7 months
3	Algerian	yes	p.R129*/p.R129*	F	19	15	hypoglycemia, asthenia, melanoderma	no MC ttt but 4 adrenal crises with ↑renin ↓aldosterone (4, 7, 8 and 10 yrs) <b>SW</b> at 15 and 18 yrs	menarche (11 yrs), NI menstrual cycle	NI imaging (15 yrs)	NI	no
4a	French/ Algerian	no	p.R71*/p.R129*	F	30	1.5 (onset) /12	hypoglycemic convulsions following gastroenteritis	MC ttt at 2 yrs (↑renin)	menarche (11 yrs), two children	-	-	no
4b				F	23	10	hypoglycemic convulsions following gastroenteritis	no MC ttt but ↑renin	-	-	-	no
5	French	no	p.V665Pfs*29/p.V665Pfs*29	M	14	19	hypoglycemic convulsions on ENT infections	no	onset of puberty at 12 yrs low testosterone at 13 yrs	NI imaging (11 yrs)	NI	no
6	Turkish	yes	p.A704Sfs*19/p.A704Sfs*19	F	18	8	hypoglycemia, asthenia, melanoderma, weight loss, fever, <b>SW</b>	MC ttt	menarche (12.5 yrs)	-	<b>transient subclinical hypothyroidism</b> (TSH: 6.8 mUI/L at 5yrs)	no
7	Moroccan	yes	p.A863E/p.A863E	M	5	13	hypoglycemic convulsions	no	<b>precocious puberty with 3 nodular testis</b>	NI imaging (4 yrs)	NI	no
8	Mauritian	yes	p.M1?/p.M1?	F	8	9	hypoglycemic coma, <b>SW</b>	MC ttt	no pubertal symptoms	-	NI	no
9	Algerian	yes	p.R379*/p.R379*	M	10	22 (onset) /8yrs	Misdiagnosed at 22 months (several hyperthermic convulsions, psychomotor retardation, sodium valproate ttt), all symptoms improved after glucocorticoid therapy initiated at 8 yrs	no	<b>Leydig cell adenoma (5 yrs) following by precocious puberty</b>	subNI imaging at 6 yrs ( <b>LVEF at 75%</b> )	<b>subclinical hypothyroidism</b> (TSH: 3.5 mUI/L at 5 yrs and 10.5 at 7 yrs), thyroid hormone treatment	no
10a	French	no	p.P437L/p.P437L	M	57	4 yrs	melanoderma, asthenia	salt craving, MC ttt	NI puberty	-	-	no
10b				M	51	18	melanoderma, asthenia	salt craving, MC ttt	NI testicular function at 49 yrs	NI imaging (51 yrs)	NI	no
10c				F	4*	16	familial story, deceased at 4 yrs	MC ttt	-	-	-	no
11a	Algerian	yes	p.R129*/p.R129*	M	6	2	<b>SW</b>	SW (2 months, 4 yrs), MC ttt	<b>cryptorchidism (surgery)</b>	NI imaging (2 yrs)	-	Brother at 8 months
11b				M	8	4 yrs	hypoglycemia (NI at 3 yrs)	no	<b>cryptorchidism (surgery)</b>	NI imaging (2 yrs)	-	Brother at 8 months
12	French	no	p.R71*/del ex2-3	M	35	10	<b>SW</b>	SW, MC ttt	<b>bilateral TART, azoospermia</b>	-	NI	no
13	Algerian	yes	p.M337V/p.M337V	F	9	8	melanoderma, asthenia	↑renin, ↓aldosterone (16 months, 12 yrs), salt, no MC ttt	no pubertal symptoms	-	NI	Sister at 4 yrs

-: not determined, M: male, F: female, NI: normal, \*: deceased, yrs: years, ttt: treatment, MC: mineralocorticoid, GC: glucocorticoid, SW: salt wasting, ↓: decreased ↑: increased, LVEF: left ventricular fraction, ENT: ear, nose, throat. Major abnormalities are in bold. For two patients (4a and 9) the age of diagnosis was late despite an earlier onset.

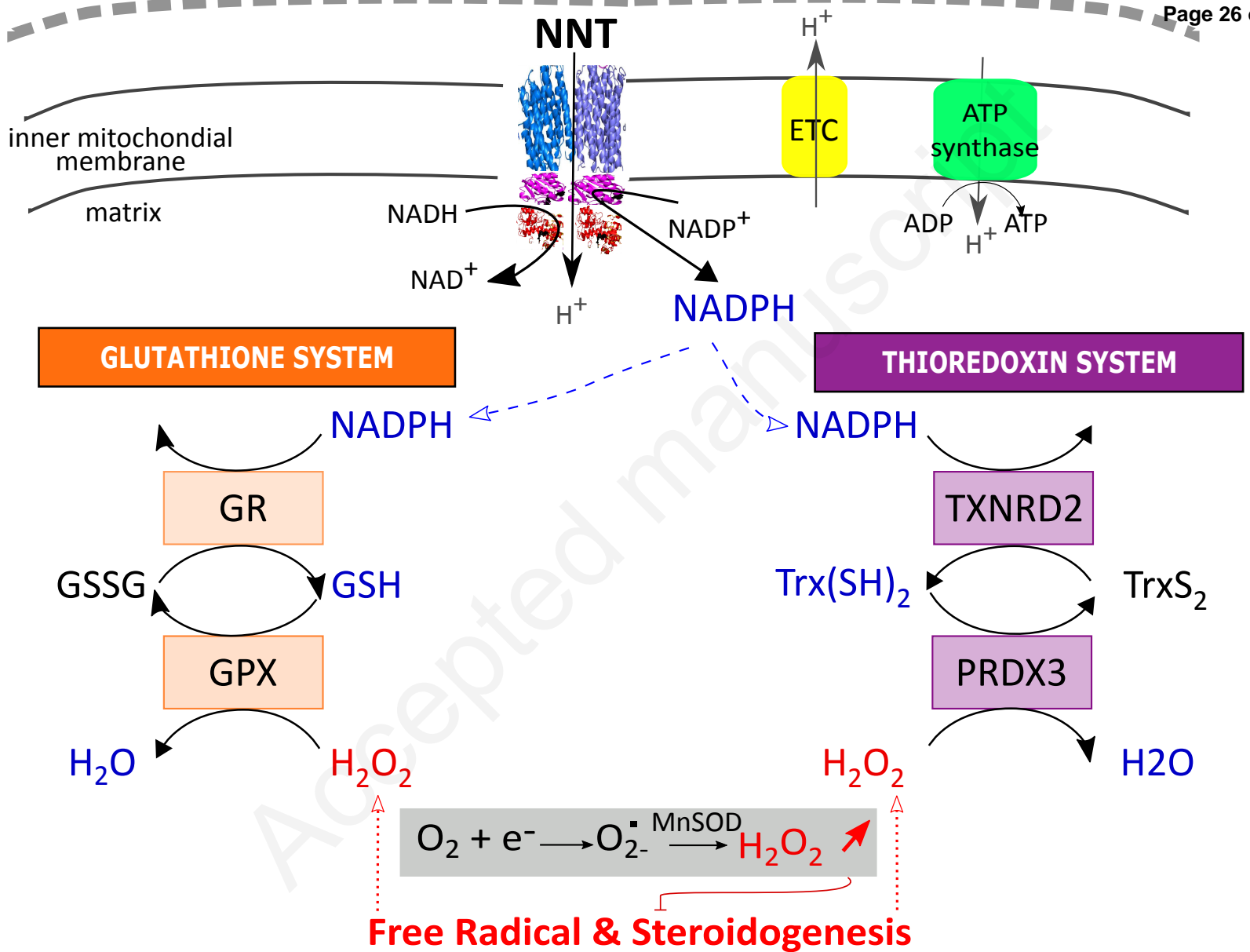

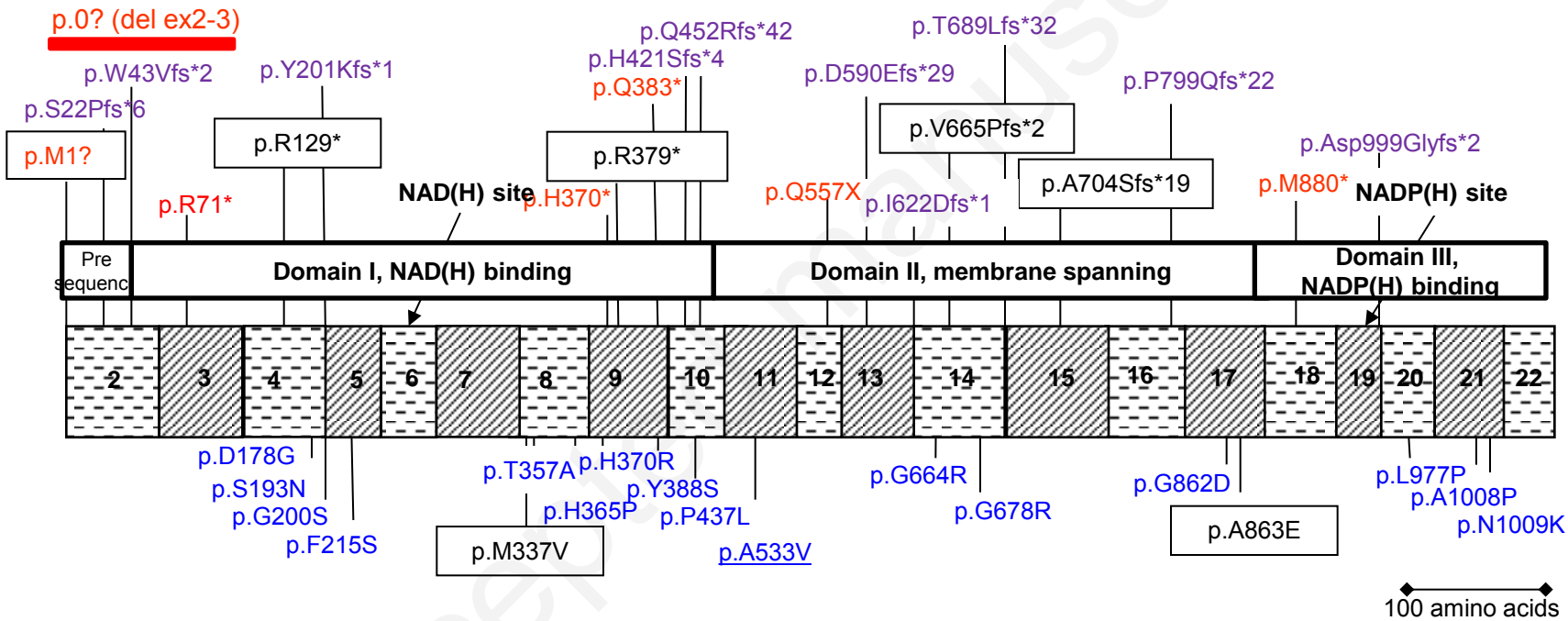

## p.M337

Human : VLFNKEMIESMKEGSVVVDLAAEAGGNFET  
 Bovine : ILFNKEMIESMKEGSVVVDLAAEAGGNFET  
 Mouse : VLF SKEMIESMKEGSVVVDLAAEAGGNFET  
 C. elegans : ILITEEMIKSMKPGSVVVDLAAESGGNIAT  
 E. coli : KLITREMVD SMKAGSVIVDLAAQNGGNCEY  
 A. acetabulum: KLILKDMIESMKPGSVVVDLAAENGGNIET

## p.A863

Human : EGFLN NNLLTIVGALIGSSGAILS YIMCV.  
 Bovine : EGFLN NNLLTIVGALIGSSGAILS YIMCV.  
 Mouse : EGFLN NNLLTIVGALIGSSGAILS YIMCV.  
 C. elegans : EGFLD NSLLTVLGALIGSSGAILS SHIMCK.  
 E. coli : AGFMLSNDLLIVTGALV GSSGAILS YIMCK.  
 A. acetabulum: G- SVLDN NNLLTIVGALIGSSGAILS AIMCK.

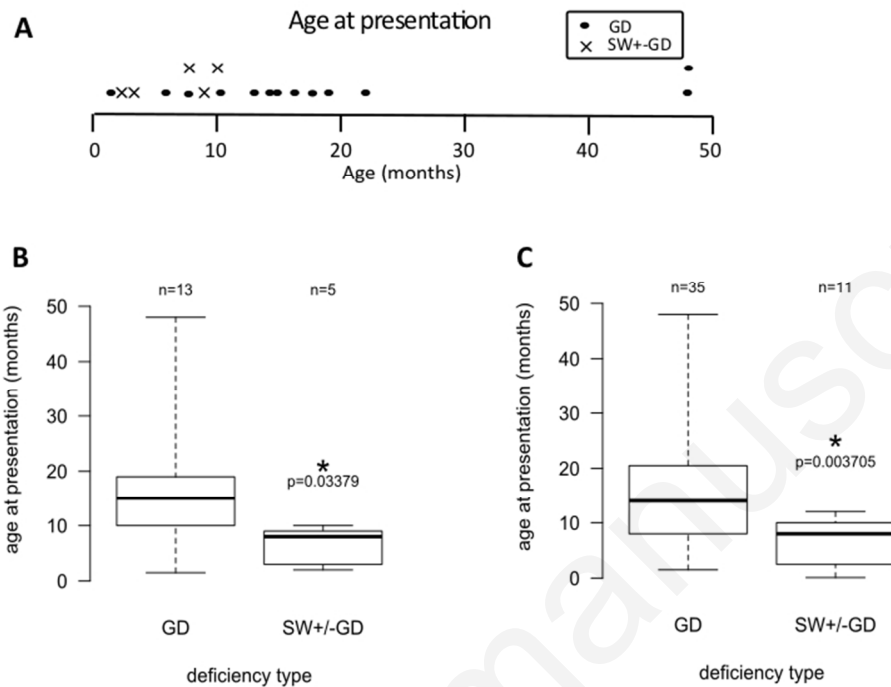

**Figure 4:** **A.** Age at presentation for the patients of our cohort GD: glucocorticoid deficiency, SW: salt wasting. **B&C.** Difference in age at presentation (Kruskal-Wallis test, \*: significance at  $p < 0.05$ ) between the group of patients with glucocorticoid deficiency and the group with salt wasting +/- glucocorticoid deficiency within our cohort ( $p$ -value = 0.03379\*) (**B**); our data aggregated with the data available in the literature ( $p$ -value = 0.003705\*) (**C**).  
67x50mm (300 x 300 DPI)